

GKSM Govt. College Tanda

Urmar

**Department of
Computer Science
&
Application**

E-Contents By: Asist. Prof.

**Vinay Kumar
Shaveta Sangar
Pooja Sharma**

Computer Memory



What is Computer Memory

- Computer **memory** is any physical device capable of storing information temporarily, like RAM (random access memory), or permanently, like ROM (read-only memory).
- Memory devices utilize integrated circuits and are used by operating systems, software, and hardware.

Why is memory important or needed for a computer?

- Each device in a computer operates at different speeds and computer memory gives your computer a place to quickly access data.
- If the CPU had to wait for a secondary storage device, like a hard disk drive, a computer would be much slower.

Types of Computer Memory

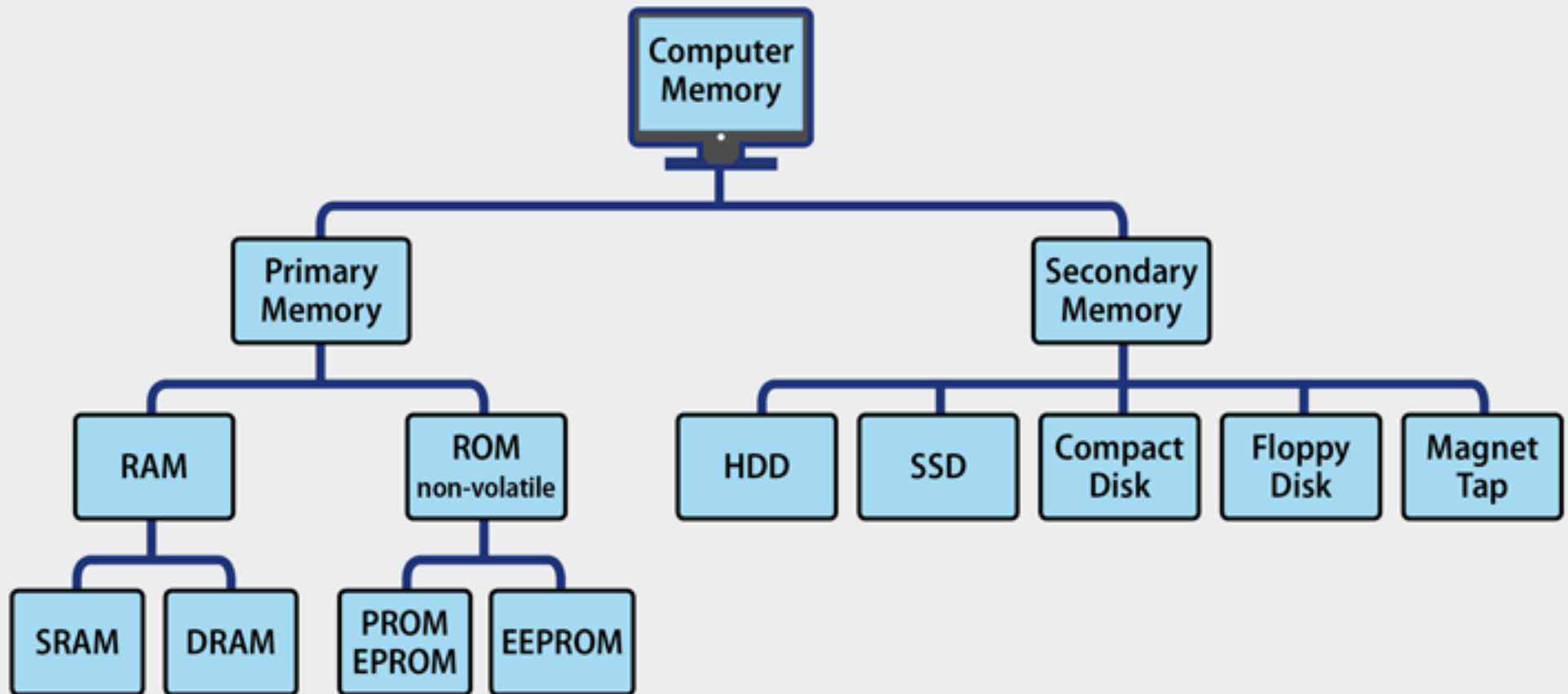

Primary Memory

- This is the main memory of the computer. CPU can directly read or write on this memory. It is fixed on the motherboard of the computer.
- Primary memory is further divided in two types:
 - 1.RAM(Random Access Memory)
 - 2.ROM(Read Only Memory)

RAM(Random Access Memory)

- RAM is a temporary memory. The information stored in this memory is lost as the power supply to the computer is turned off. That's why it is also called **Volatile Memory**.
- It stores the data and instruction given by the user and also the results produced by the computer temporarily

ROM(Read only Memory)

- Information stored in ROM is permanent in nature,i.e., it holds the data even if the system is switched off.
- It holds the starting instructions for the computer. ROM cannot be overwritten by the computer. It is also called Non-Volatile Memory.



Secondary Memory

- This memory is permanent in nature. It is used to store the different programs and the information permanently (which were temporarily stored in RAM). It holds the information till we erase it.
- **Different types of secondary storage devices are:**
 1. Hard Disc, Compact Disc,
 2. DVD, Pen Drive,
 3. Flash Drive, etc.

Hard Disc Drive

- Hard disk drive is made up of a series of circular disks called **platters** arranged one over the other almost $\frac{1}{2}$ inches apart around a **spindle**.
- Disks are made of non-magnetic material like aluminum alloy and coated with 10-20 nm of magnetic material.



CD Drive

- CD stands for **Compact Disk**. CDs are circular disks that use optical rays, usually lasers, to read and write data.
- They are very cheap as you can get 700 MB of storage space for less than a dollar. CDs are inserted in CD drives built into CPU cabinet.
- They are portable as you can eject the drive, remove the CD and carry it with you.

DVD Drive

- DVD stands for **Digital Video Display**. DVD are optical devices that can store 15 times the data held by CDs.
- They are usually used to store rich multimedia files that need high storage capacity. DVDs also come in three varieties – read only, recordable and rewritable.

Pen Drive

- Pen drive is a portable memory device that uses solid state memory rather than magnetic fields or lasers to record data.
- It uses a technology similar to RAM, except that it is nonvolatile. It is also called USB drive, key drive or flash memory.

Blu Ray Disk

- Blu Ray Disk (BD) is an optical storage media used to store high definition (HD) video and other multimedia files.
- BD uses shorter wavelength laser as compared to CD/DVD. This enables writing arm to focus more tightly on the disk and hence pack in more data. BDs can store up to 128 GB data.

Primary Vs Secondary Memory

Parameter

Primary memory

Secondary memory

Nature

The primary memory is categorized as volatile & nonvolatile memories.

The secondary memory is always a non-volatile memory.

Alias

These memories are also called internal memory.

Secondary memory is known as a Backup memory or Additional memory or Auxiliary memory.

Access

Data is directly accessed by the processing unit.

Data cannot be accessed directly by the processor. It is first copied from secondary memory to primary memory. Only then CPU can access it.

Formation

It's a volatile memory meaning data cannot be retained in case of power failure.

It's a non-volatile memory so that that data can be retained even after power failure.

Memory Units

- Data in the computer's memory is represented by the two digits 0 and 1.
- These two digits are called **Binary Digits** or **Bits**.
- A bit is the smallest unit of computer's memory.
- Bits=0,1

1 Byte= 8 bits(e.g,11001011)

1 KB(kilobyte) = 1024 Bytes

1 MB(megabyte) = 1024 KB

1 GB(Gigabyte) = 1024 MB

1 TB(Terabyte) = 1024 GB

Thanks